



Holy-wood Academy, Kolhapur's
SANJEEVAN ENGINEERING AND TECHNOLOGY INSTITUTE

Sanjeevan Knowledge City, Somwar Peth- Injole, Panhala, Tal. Panhala, Dist. Kolhapur- 416 201

Phone : 0231 - 2686600 / 23 / 24 / 28 Fax : 0231 - 2686629

■ Approved By AICTE - New Delhi ■ Recognized by Govt. of Maharashtra & DTE ■ Affiliated to DBATU, Lonere.

Website : www.seti.edu.in Email : office@seti.edu.in / admission@seti.edu.in

EN 6315

Department of Mechanical Engineering

Date- 13/05/2023

To,
New Melting Centre Pvt. Ltd.
Gat No.678 / 679 (Part) Kushire,
Tal.Panhala, Dist : Kolhapur
Maharashtra - 416229

Subject: Regarding Permission for Industrial Visit

Respected Sir,

Our institute is established in 2009 in a view to impart engineering education to under graduate and post graduate students. Mechanical Engineering is one of the six programs run by the institute for under graduate students.

As per of the curriculum of Dr. Babasaheb Ambedkar Technological University Lonere (D.B.A.T.U.), for Third Year Mechanical Engineering students, an industrial visit is required. This will help students to visualize the knowledge about various manufacturing processes which they have gained under the course of "Manufacturing Process-II".

In this regard, we would like to visit your esteemed organization. So, you are kindly requested to permit our students to visit your company preferably on 16th March, 2023.

Thanking you.

Prof. Praveen S. Atigre
Subject Incharge
Mechanical Engg. Department

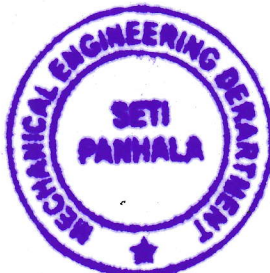

Prof. Sardar B. Deshmukh
HOD
Mechanical Engg. Department



Holy-wood Academy, Kolhapur's
SANJEEVAN ENGINEERING AND TECHNOLOGY INSTITUTE
Sanjeevan Knowledge City, Somwar Peth- Injole, Panhala, Tal. Panhala, Dist. Kolhapur- 416 201
Phone : 0231 - 2686600 / 23 / 24 / 28 Fax : 0231 - 2686629

■ Approved By AICTE - New Delhi ■ Recognized by Govt. of Maharashtra & DTE ■ Affiliated to DBATU, Lonere.

Website : www.seti.edu.in Email : office@seti.edu.in / admission@seti.edu.in

EN 6315

Department of Mechanical Engineering

Date- 13/05/2023

NOTICE

All the students of Third Year Mechanical Engineering are hereby informed that, an Industrial Visit for the subject Manufacturing Process-II is arranged. The details are as follows.

Name of Company	New Melting Centre Pvt. Ltd.
Location	Gat No.678 / 679 (Part) Kushire, Tal.Panhala, Dist : Kolhapur Maharashtra - 416229
Day & Date	Tuesday 16/05/2023
Timing	10.00 am
Subject & Content	Manufacturing Process-II (Different Manufacturing Processes)

Attendance is compulsory for all Third Year Students.

P.S. Atigre
Prof. P. S. Atigre
Subject Incharge
Mechanical Engg. Department

Sardar B. Deshmukh
Prof. Sardar B. Deshmukh
HOD
Mechanical Engg. Department





Holy-wood Academy, Kolhapur's
SANJEEVAN ENGINEERING AND TECHNOLOGY INSTITUTE
 Sanjeevan Knowledge City, Somwar Peth- Injole, Panhala, Tal. Panhala, Dist. Kolhapur
 Pin- 416 201. (Maharashtra) Phone : 0231 - 2686600, 21 Fax : 0231 - 2686629

Approved By AICTE, New Delhi ■ Recognized by Govt. of Maharashtra & DTE ■ Affiliated to Dr. Babasaheb Ambedkar Technological University, Raigad (DBATU).
 Website : www.seti.edu.in Email : principal@seti.edu.in / office@seti.edu.in **EN 6315**

Department of Mechanical Engineering
 Industrial Visit (Attendance)

Name of Company : New Melting Centre Pvt. Ltd

Date & Time : 16/05/2023 (10:00 am to 12:00 pm)

Class: TY Mechanical

Academic Year : 2022-23 Sem-II

Roll No.	Name of Student	Signature	Roll No.	Name of Student	Signature
1	KHOCHIKAR AHAD SAMAD	<i>Ashhadkar</i>	37	LOHAR DHIRAJ SHIVAJI	<i>Dhiraj</i>
2	KADAM NIKHIL BHIMRAO	<i>Nikhil</i>	38	JADHAV NIRANJAN JAYWANT	—
3	MANE PRADIP SHAMRAO	<i>Pradip</i>	39	MHAMULKAR ABHIJIT HINDURAO	—
4	KUMBHAR PRANALI BABASAHEB	<i>Bumbar</i>	40	KHOT SWAPNIL SHASHIKANT	—
5	GUJAR PRANAV JOTIRAM	—	41	NAGARI DIPAK DEVENDRA	<i>Dipak</i>
6	MAGDUM PRATHMESH SUDHIR	<i>Prathmesh</i>	42	BHAT SAHIL PUNDALIK	—
7	KHOT SHUBHAM TUKARAM	<i>Shubham</i>	43	BAWALE VISHWESH PRASANNA	—
8	SHETE SHUBHAM MARUTI	<i>Shubham</i>	44	PATIL NIKHIL DNYANDEV	—
9	SHINDE SIDDHESH SUNIL	<i>Siddhesh</i>	45	SAWRATKAR VISHAL UTTAM	—
10	BENDHALE SIDDHESH SANTOSH	<i>Siddhesh</i>	46	TARALEKAR PRUTHVIRAJ CHANDRAKANT	<i>Taralekar</i>
11	POWAR SOURAV SHASHIKANT	<i>Sourav</i>	47	JARAG SIDDESH VIKRAM	—
12	NAIK SHRIDHAR YUVRAJ	—	48	SHINDE CHAITANYA DILIP	—
13	SHIKHARE PRAMOD GUNDA	—	49	KHADE ROHIT VISHWAS	<i>Rohit</i>
14	SHIKHARE NILESH SHIVAJI	—	50	SATHAM DIGAMBAR SUNIL	—
15	DHERE SAURABH SATISH	—	51	PADALKAR ANIKET ASHOK	<i>Aniket</i>
16	DHERE HARSH SATISH	—	52	GHATAGE SARADAR KRUSHNAT	—
17	DESAI VISHWAJEET VIKAS	—	53	BAGADI DHAIRYASHIL HINDURAO	—
18	KADAVEKAR ANIKET RAJENDRA	—	54	PATIL SUSHANT SANJAY	—
19	SAWANT SUNIL BHAGAWAN	<i>Sawant</i>	55	WAIKAR RAHIL ANIS	—
20	KHOT VIVEK MADHUKAR	<i>V.M. Khote</i>	56	PATIL SHUBHAM RAGHUNATH	—
21	ARAB MOHMADSAAD ZAKIRHUSEN	—	57	NAGARJI ADIL KASAM	—
22	JADHAV OMKAR	—	58	SAVARE AKANKSHA AKARAM	<i>Akanksha</i>
23	JADHAV ALIAS MITHARI KAUSTUBH R.	—	59	KONDE SAMRUDDHI BABASAHEB	<i>Konde</i>
24	GARAD NILESH JAYSING	—	60	WANGIKAR RUTUJA AAPPASO	<i>Rutuja</i>
25	PATIL ANISH VASANT	—	61	KUMBHAR ABHIJEET VILAS	—
26	KAMBLE SHUBHAM BAJIRAO	<i>Shubham</i>	62	CHOUGULE SUMIT MANOHAR	<i>Sumit</i>
27	BAHADURE NITIN AMBADAS	—	63	KHOT RUSHIKESH NAMDEV	<i>Rushikesh</i>

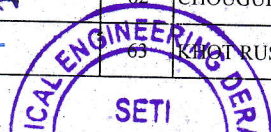



Holy-wood Academy, Kolhapur's
SANJEEVAN ENGINEERING AND TECHNOLOGY INSTITUTE
Sanjeevan Knowledge City, Somwar Peth- Injole, Panhala, Tal. Panhala, Dist. Kolhapur
Pin- 416 201. (Maharashtra) Phone : 0231 - 2686600, 21 Fax : 0231 - 2686629

Approved By AICTE, New Delhi ■ Recognized by Govt. of Maharashtra & DTE ■ Affiliated to Dr. Babasaheb Ambedkar Technological University, Raigad (DBATU).

Website : www.seti.edu.in Email : principal@seti.edu.in / office@seti.edu.in

EN 6315

Department of Mechanical Engineering
Industrial Visit (Attendance)

Name of Company : New Melting Centre Pvt. Ltd

Date & Time : 16/05/2023 (10:00 am to 12:00 pm)

Class: TY Mechanical

Academic Year : 2022-23 Sem-II

Roll No.	Name of Student	Signature	Roll No.	Name of Student	Signature
28	POPHALE YASH PRAVIN	—	64	SASWADE SHRIKANT ARUN	<u>Shrikant</u>
29	MANE PAVAN MAHADEV	—	65	POWAR SHUBHAM SANJAY	—
30	SHINDE SAHIL NITIN	—	66	CHOUGULE SHIDHARTH SAMBHAJI	—
31	SAPALE GAURESH RAJESH	—	67	MULLA JUBER SAMEER	—
32	KATE RAJVARDHAN KAMALAKAR	<u>R. Kate</u>	68	MOHITE VIVEK SHRIKANT	—
33	LOHAR PRATHAMESH MANIK	—	69	SHINDE PRATHAMESH BHAGAVAN	<u>B. Shinde</u>
34	KADAM PRANAV JAGADISH	—	70	SATHE MAHESH SARJERAO	—
35	GURAV ROHIT HINDURAO	<u>R. Gurav</u>	71	PATIL VAIBAV RANGRAO	—
36	JAGDALE ABHISHEK VIJAY	—			
					<u>P. R. Patil</u> Faculty Signature

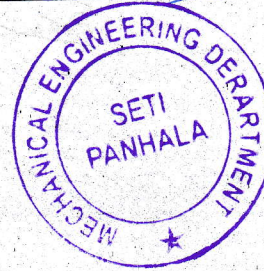



Holy-wood Academy, Kolhapur's
SANJEEVAN ENGINEERING AND TECHNOLOGY INSTITUTE
Sanjeevan Knowledge City, Somwar Peth- Injole, Panhala, Tal. Panhala, Dist. Kolhapur- 416 201
Phone : 0231 - 2686600 / 23 / 24 / 28 Fax : 0231 - 2686629

■ Approved By AICTE - New Delhi ■ Recognized by Govt. of Maharashtra & DTE ■ Affiliated to DBATU, Lonere.

Website : www.seti.edu.in Email : office@seti.edu.in / admission@seti.edu.in

EN 6315

Department of Mechanical Engineering

Date- 16/05/2023

To,
New Melting Centre Pvt. Ltd.
Gat No.678 / 679 (Part) Kushire,
Tal.Panhala, Dist : Kolhapur
Maharashtra - 416229

Respected Sir,

We would like to extend our sincere thanks to you for providing an opportunity to visit your esteemed and reputed organization on 16th March 2023. We are glad to say that the response from the students was enthusiastic. The information presented by you is definitely useful to our students for enhancing their knowledge about different manufacturing processes.

We genuinely thank you once again for the support and time given by you and we sincerely hope that you would continue to extend your valuable support in our future initiatives as well.

Thanking you.

P. S. Atigre

Prof. Praveen S. Atigre
Subject Incharge
Mechanical Engg. Department

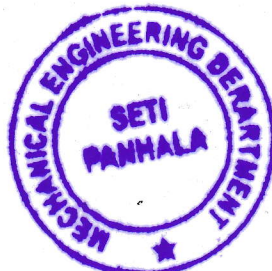

Sardar B. Deshmukh

Prof. Sardar B. Deshmukh
HOD
Mechanical Engg. Department



*Visited
PM
16/05/2023*

REPORT

Industrial Visit at New Melting Centre Pvt. Ltd.

Class: T.Y. Mechanical
Subject: Manufacturing Process-II
Industry Visited: New Melting Centre, Kushire
Address: Unit 1 Gat No.678 / 679 (Part), Kushire, Tal.Panhala,
Dist : Kolhapur Maharashtra – 416229
Day & Date: Tuesday 16/05/2023
Time: 10-12 pm
Faculty Members: Prof. Praveen S. Atigre
Prof. Dhananjay V. Patil

Introduction :

An Industrial visit at New Melting Centre, Kushire was organized by Department of Mechanical Engineering for Third Year Students on 16th May 2023. The industrial visit was witnessed by students of the class, who were accompanied by the faculty Mr. Praveen S. Atigre and Prof. Dhananjay V. Patil.

Aim of the Visit:

Industrial visit is considered as one of the tactical methods of bridging the gap between theoretical and practical knowledge. The main aim of industrial visit is to provide an exposure to the students about practical working environment .Industrial visits also provide students a good opportunity to gain full awareness about industrial practices and new technologies. Through this industrial visit, the efforts are taken by the department to provide an exposure to students about different manufacturing processes.

About the Company:

New Melting Centre is a 27 years old company specialized in producing high quality casting & equipped with best manufacturing machineries such as CNC's VMC's etc. This industry is located at Kushire MIDC, Kolhapur.

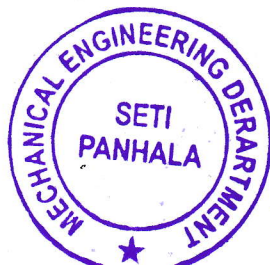

Infrastructure :

Land & Building :

Foundry : 4253.24 Sq.mtr.

Machine Shop : 4115.65 Sq.mtr.

New Foundry & Machine Shop : 34.8 K Sq.mtr.

Capacity : Produce 1500 MT/ Month C.I. & SGI Casting parts

Products of the Company:

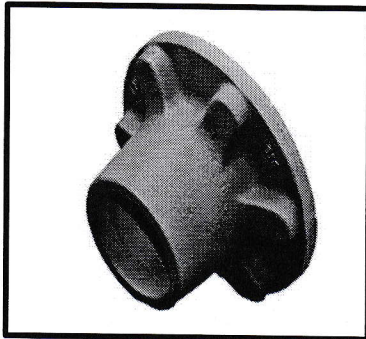

Wheel Hub

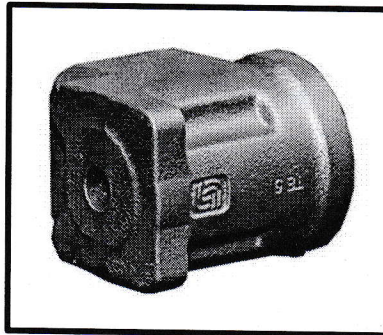

Steering Housing

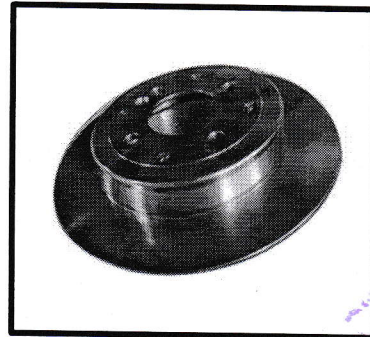

Disc (Rear Wheel Brake)

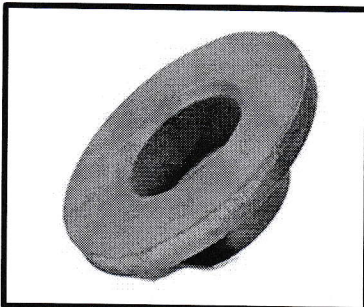

Brake Disc

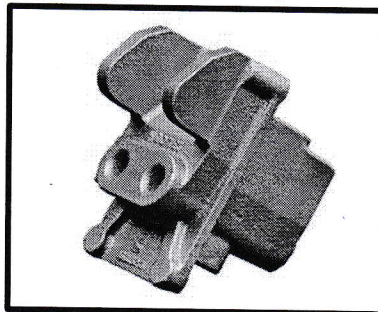

Brake Valve

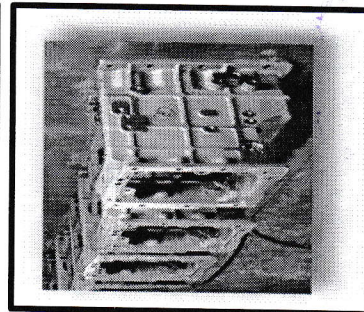

30HP Front TC

Clients of the Company:

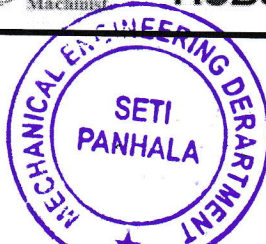

Machine Shop Division: Different Product lines are
ILJIN Line
ILJIN Line – Robotic Operation
EMERSON Line
DANFOSS Line

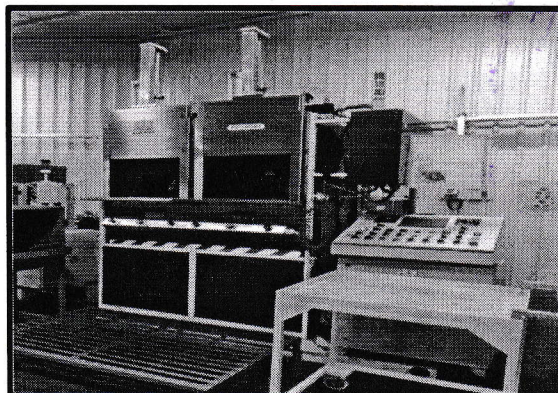
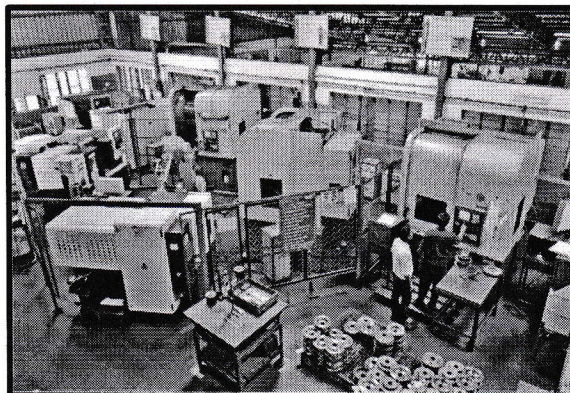
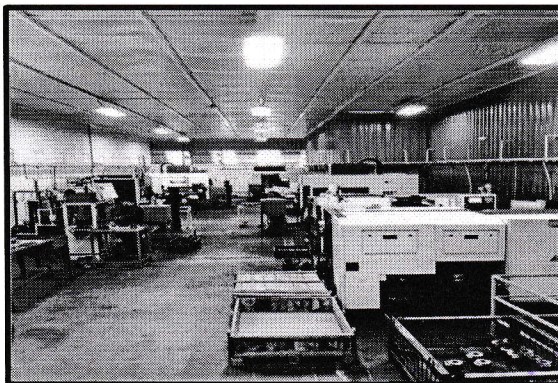
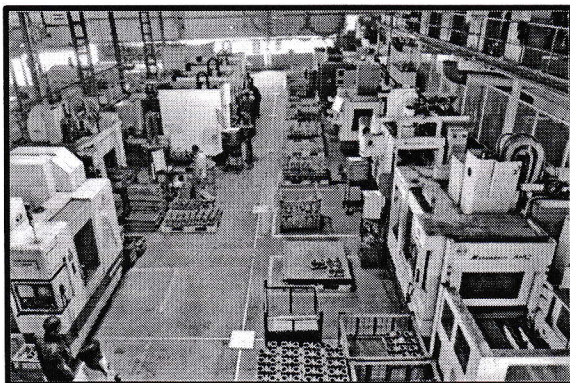

Photograph No. 1 : Machine Shop Division:

In this machine shop students observed different manufacturing processes such as turning, step turning, facing, grinding, drilling, chamfering etc. Also they observed working of advance machineries such as CNC's & VMC's.

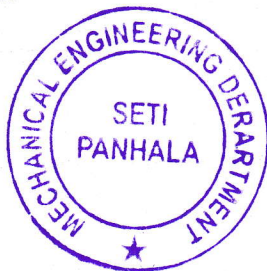

Inspection Facilities

CMM : Make- Mitutoyo, Model- CRT-AS7106, Size- X-700mm, Y-1000mm, Z-600mm

CMM : Make- Electronica, Model- RUBY CNC 564, Size- X-500mm, Y-600mm, Z-400mm

Auto Gauging Machine : Make – APPOLO

Profile Projector : Make- Innovative, Model- H-36, Size- X-200mm, Y-100mm

Contracer : Make- Mitutoyo, Model- CV-2100M4, Size- X-100mm,Z-50mm

Surface Taster : Make- Mitutoyo, Model- SJ-410, Size- 0 to 25mm

2D Height Gauge : Make- Trimos, Model- VT 600MO, Size- 0 to 600 mm

Tool Pre-Setter : Make- Zoller, Model- SMILE 420, Size- 0 to 420mm

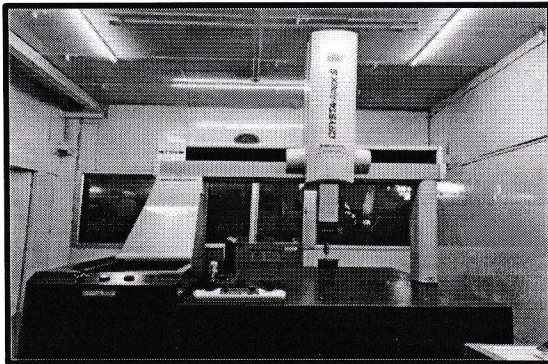

CMM

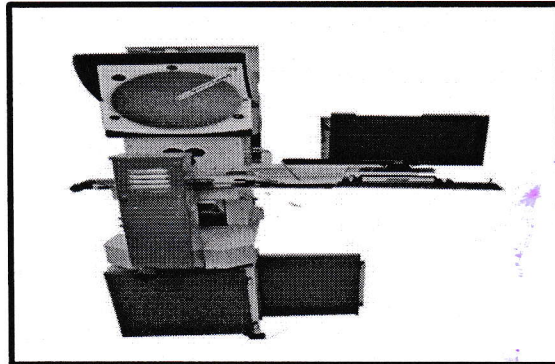

Optical Profile Projector

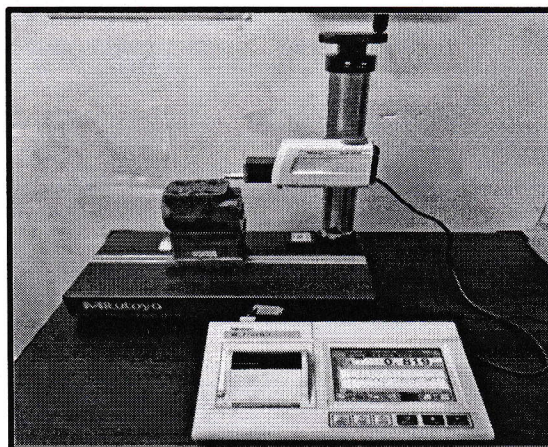

Mitutoyo Surface Tester



2D Height Gauge

In this shop students observed different inspection / measuring instruments such as Height Gauge, Vernier Caliper, Optical profile projector, surface roughness tester, CMM etc.



Visit Photographs :

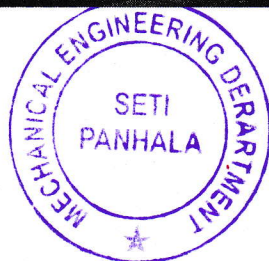

Visit Photographs :

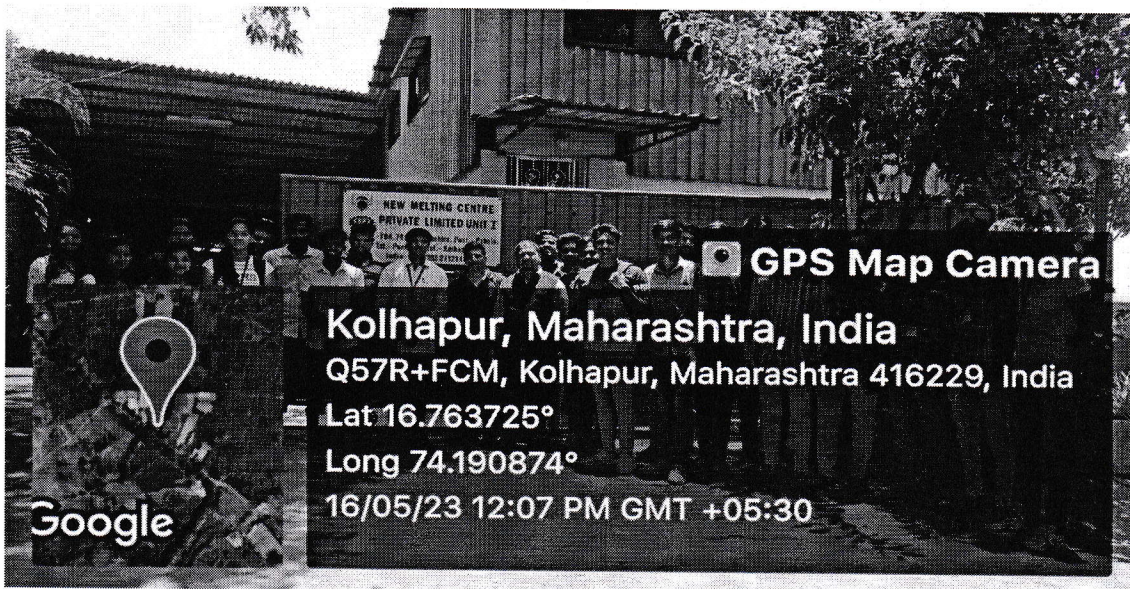

Conclusion :

An Industrial visit at New Melting Centre, Kushire was successfully completed by the students of Third Year Mechanical Engineering on 16th May 2023. During the visit students observed different manufacturing processes such as turning, step turning, facing, grinding, drilling, chamfering etc. Also they observed working of advance machineries such as CNC's & VMC's. In inspection section, students observed different inspection / measuring instruments such as Height Gauge, Vernier Caliper, Optical profile projector, surface roughness tester, CMM etc.

Students Name & Signature

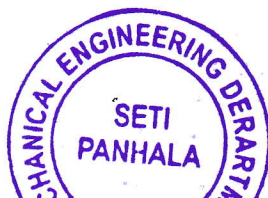

Faculty Signature

P. S. AHIR